

# PREVOST

## Instruction Sheet

## IS-18025 A

### KNEELING LEVEL SENSOR REPLACEMENT


REVISION : A THIS BULLETIN SUPERSEDES PREVIOUS VERSION.

2019 06 03 Reference for air spring clearance values updated


Description:

This instruction sheet shows how to replace kneeling level sensor #21643575 by sensor #22194741.

#### APPLICATION FOR FRONT I-BEAM AXLE SUSPENSION

Model	VIN		KIT TO ORDER	PAGE
H3-45 coaches Model Year : 2012 - 2014	From 2PCH33499 <u>CC712007</u> up to 2PCH33498 <u>EC712504</u> incl.		132117	2
H3-45 coaches Model Year : 2014 - 2015	From 2PCH33491 <u>EC712506</u> up to 2PCH33491 <u>FC712815</u> incl.		132119	10
X3-45 coaches Model Year : 2014 - 2015	From 2PCG33493 <u>EC735538</u> up to 2PCG33491 <u>FC735796</u> incl.			
X3-45 Commuter Model Year : 2015	4RKG33497 <u>F9737001</u>			

#### APPLICATION FOR INDEPENDENT FRONT SUSPENSION (IFS)

Model	VIN		KIT TO ORDER	PAGE
H3-45 coaches Model Year : 2012 - 2013	2PCH33495 <u>CC712019</u> 2PCH33491 <u>CC712020</u> 2PCH33499 <u>DC712235</u> 2PCH33490 <u>DC712236</u> 2PCH33494 <u>DC712272</u> 2PCH33495 <u>DC712362</u>		132118	19
X3-45 coaches Model Year : 2012 - 2013	2PCG33496 <u>CC735241</u> 2PCG33498 <u>CC735242</u> 2PCG33491 <u>CC735275</u> 2PCG33493 <u>CC735276</u> 2PCG3349X <u>CC735291</u> 2PCG33490 <u>DC735382</u> 2PCG33492 <u>DC735383</u> 2PCG3349X <u>DC735387</u> 2PCG33491 <u>DC735388</u> 2PCG3349X <u>DC735390</u> 2PCG33491 <u>DC735391</u> 2PCG33493 <u>DC735392</u> 2PCG33495 <u>DC735393</u> 2PCG33497 <u>DC735444</u> 2PCG33496 <u>DC735449</u>			

#### NOTE

Material can be obtained through regular channels.

### H3 FRONT I-BEAM AXLE SUSPENSION (2012-2014)

Order kit # 132117 that contains the following parts:

Part No.	Description	Qty
22194741	SENSOR	1
132123	C-SHAPE ADAPTOR	1
132121	SENSOR ARM ASSEMBLY	1
5001745	SCR CAP HEX N500 M8X25 G8.8	4
502851	NUT HEX N500 M8-1.25	5
500321	WSH BEL SPR N500 .331X.827X.098(M8,5/16)	5
5001736	WSH FL N500 8.4X18X2 (M8,5/16)	2
504637	CABLE TIE MIDDLE SIZE	4
IS-18025	INSTRUCTION SHEET	1
FI-18025	FEUILLE D'INSTRUCTIONS	1

### PROCEDURE



#### DANGER

Park vehicle safely, apply parking brake, stop the engine. Prior to working on the vehicle, set the ignition switch to the OFF position and trip the main circuit breakers equipped with a trip button. On Commuter type vehicles, set the battery master switch (master cut-out) to the OFF position.

#### EXISTING ARM AND LEVEL SENSOR REMOVAL

1. Raise the vehicle with safe lifting equipment and procedures.
2. Remove cable ties that support the sensor wiring.
3. Unscrew the sensor connector cap and disconnect the wiring.

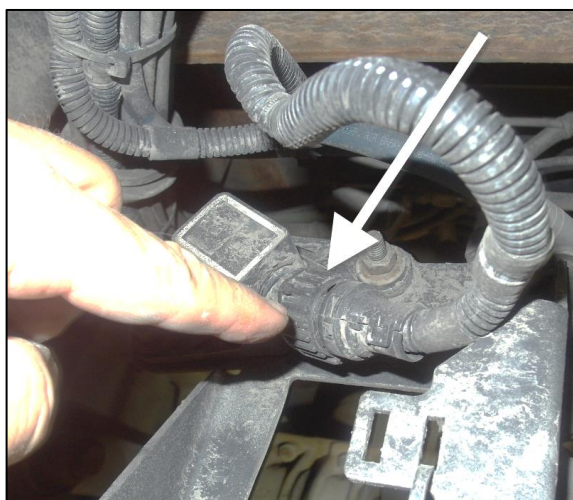


FIGURE 1

4. Disconnect the top of the valve connecting rod with the valve lever.
5. Keep fasteners for reinstallation.

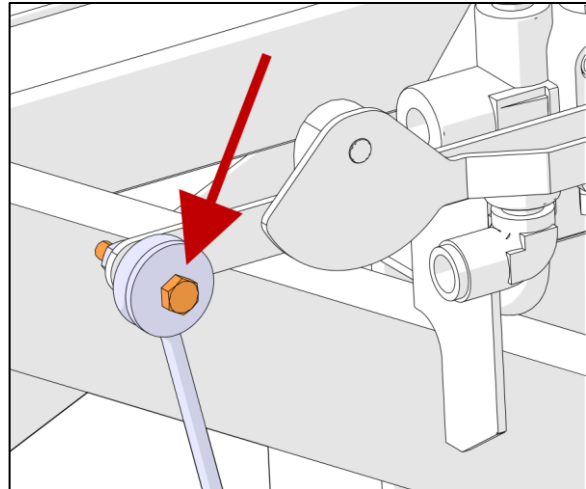


FIGURE 2

6. Dismount the existing sensor arm from the existing sensor and from the valve lever.
7. Discard the arm and the fasteners.

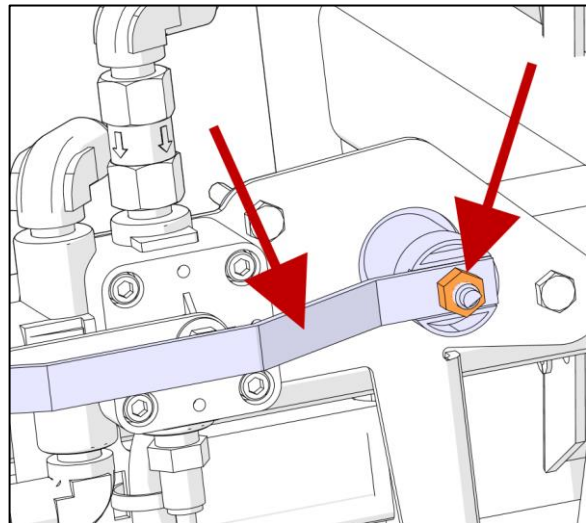


FIGURE 3

8. Dismount sensor (2 screws).
9. Discard sensor and fasteners.

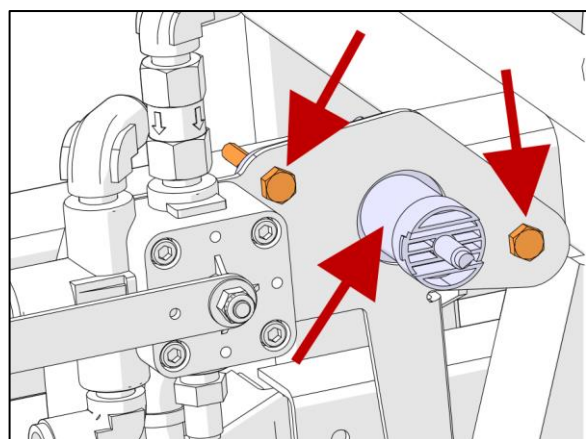


FIGURE 4

10. Remove rust on the valve lever, clean it and apply liquid lubricant. Do these operations on four faces and only half of the lever (connecting rod side).

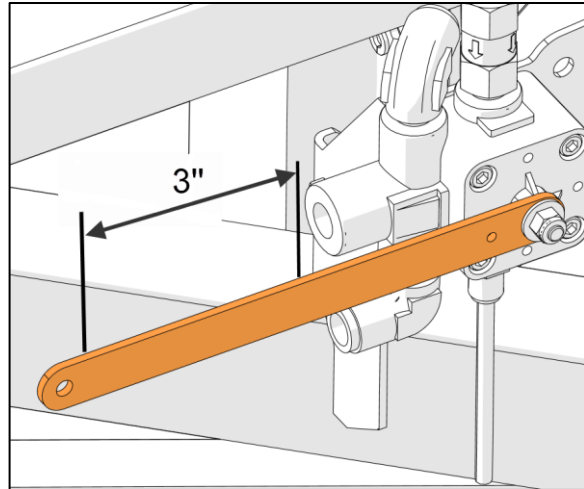


FIGURE 5

11. Remove rust on the sensor bracket mounting faces and clean it.

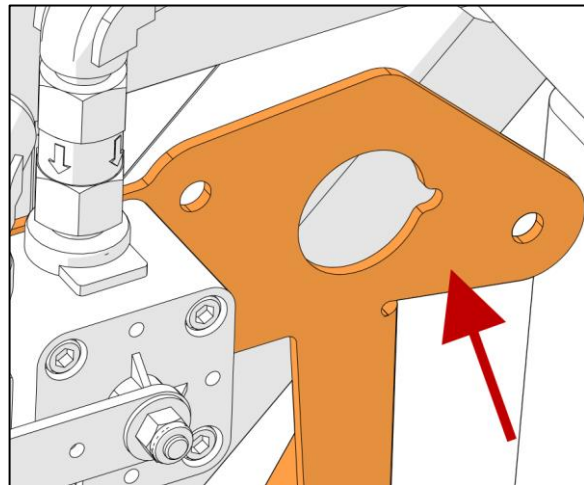


FIGURE 6

## NEW ARM AND LEVEL SENSOR INSTALLATION

12. Assemble the sensor with the "C-shape" support.

**NOTE**

*Never alter the sensor for any reason.*

*Make sure the flat on the sensor rotor is orientated as shown in Figure 7.*

**NOTE**

*Screw head must be inside the "C-shape" support.*

*Install flat washers with the screw head side and Belleville washers on the nut side.*

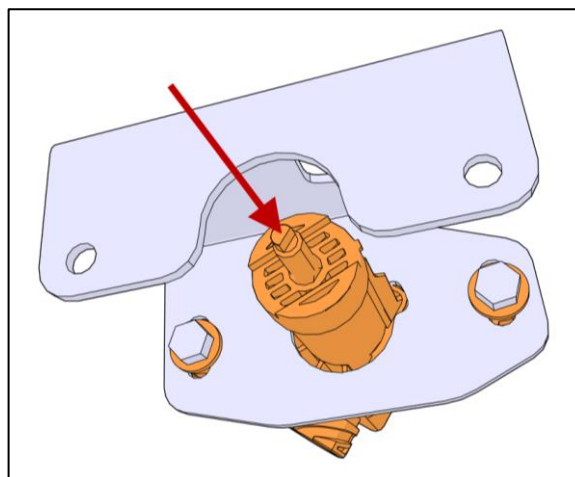


FIGURE 7

13. The "C-shape" support has arced slots to allow angle adjustment of the sensor. Orientate the sensor with the screws in the middle of the arced slots and tighten.

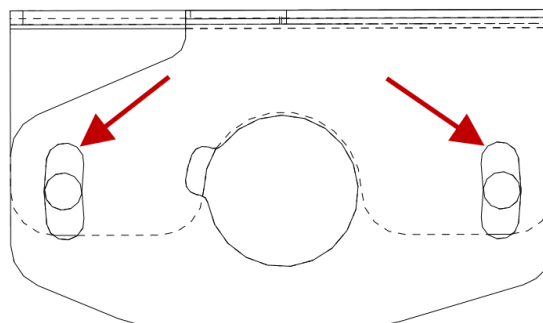


FIGURE 8

14. Install the "C-shape" support with the sensor on the vehicle structural bracket.

15. Tighten the nuts.

**NOTE**

*Screw head must be inside the "C-shape" support.*

*Install Belleville washers on the nut side.*

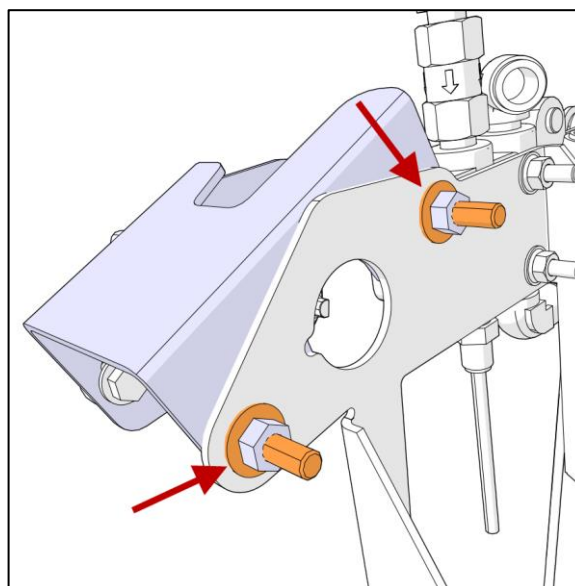
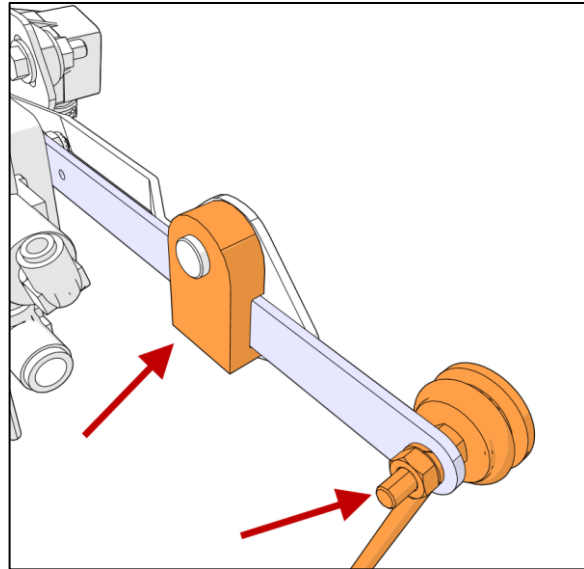


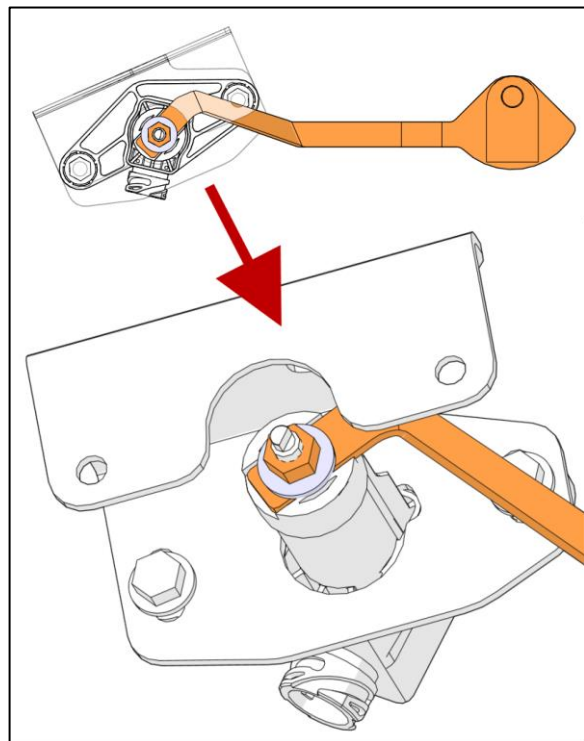
FIGURE 9

16. Install the sensor arm slider on the valve lever.
17. Reinstall the connecting rod on the valve lever.



**FIGURE 10**

18. Install new arm on the sensor. Use Belleville washer and tighten the nut.



**FIGURE 11**

19. Connect existing wiring to sensor and screw the sensor connector cap.
20. Secure the wiring with cable ties.

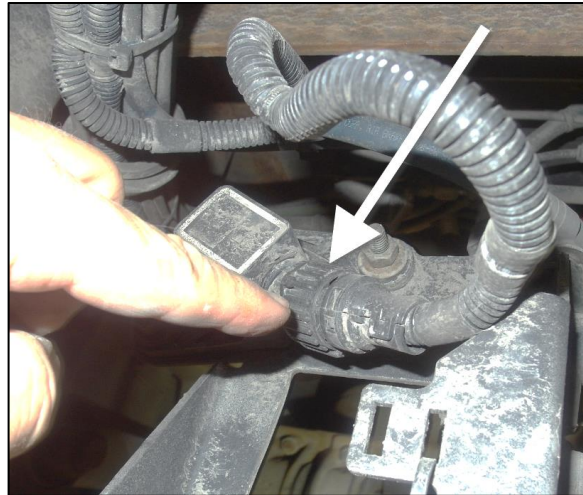
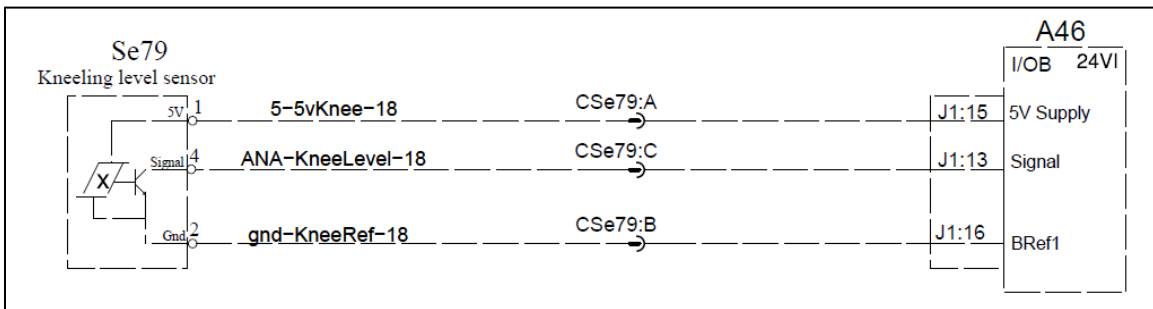
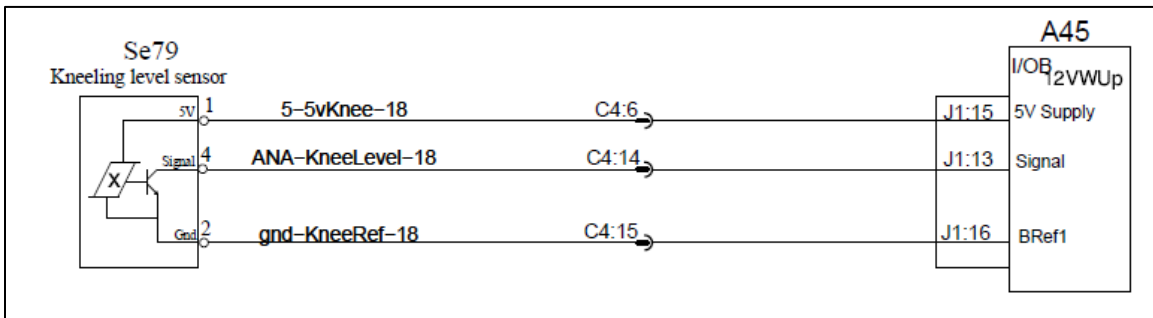


FIGURE 12

### LEVEL SENSOR ANGLE ADJUSTMENT



FOR VEHICLES C-2007 UP TO D-2363 USE DIAGRAM D061140 P32.1 REV.04 or REV.06



FOR VEHICLES D-2364 UP E-2504 USE DIAGRAM D061340 PAGE 32.1 REV.0

21. Run the vehicle 5 minutes to fill the pneumatic system with air pressure.
22. Go on the Technical Publications website at this link:
23. <https://techpub.prevostcar.com/en/manuals>
24. Select the Technical Manual tab.
25. Enter the short VIN of you vehicle.
26. Select "Maintenance" as Manual type and click on the Search button.
27. Click on "File List" button.
28. Download the Suspension section file.

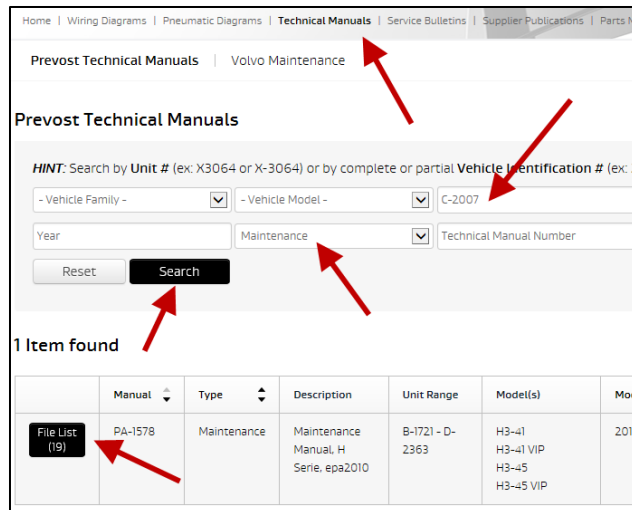


FIGURE 13

29. Use "spring clearance" words with the search tool to find the information about the clearance for I-Beam and Independent suspension clearance values.

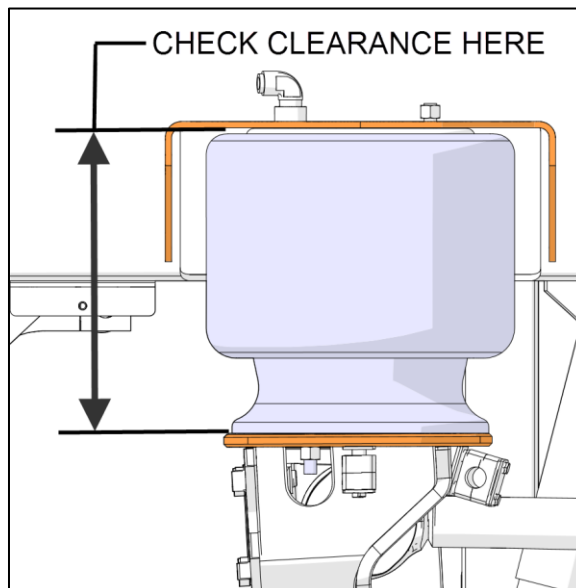


FIGURE 14

30. Into the front service compartment, locate **A46** module for vehicles C-2007 up to D-2363 or **A45** module for vehicles D-2364 up E-2504.

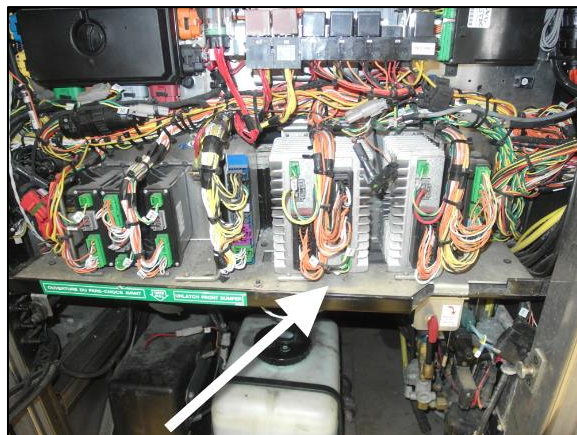


FIGURE 15



31. Locate pin 13 on connector **A46-J1** for vehicles C-2007 up to D-2363 or on connector **A45-J1** for vehicles D-2364 up E-2504.

**NOTE**

The wire color is white and the wire ID should be "KneelLevel".

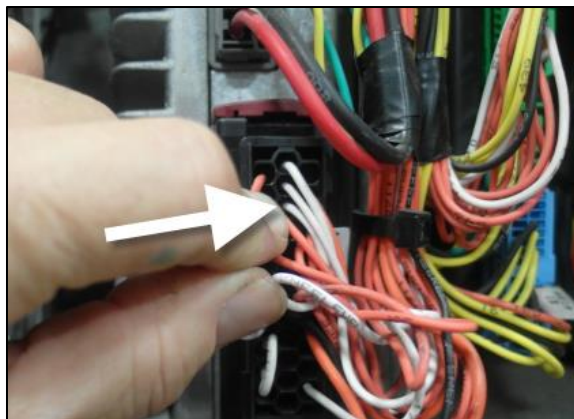


FIGURE 16

32. With a voltmeter, back probe pin 13. The voltage should be around 2.5 volts with the normal clearance.

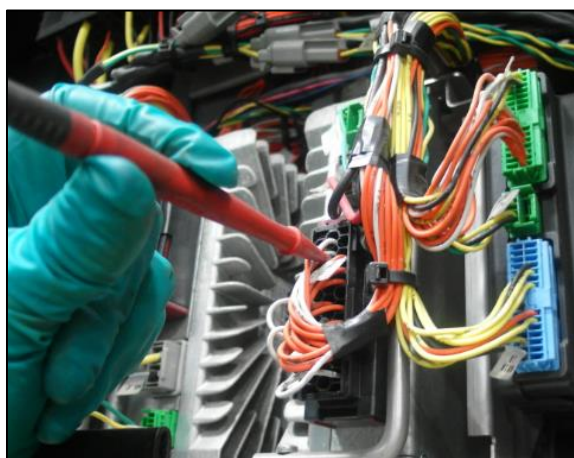


FIGURE 17

33. If the voltage is higher or lower than 2.5 volts, loosen the nuts that fix the sensor to the "C-shape" support and apply a slight rotation.
34. Tighten the nuts, check the suspension below clearance and the voltage.
35. Repeat previous steps until you reach 2.5 volts with the clearance.

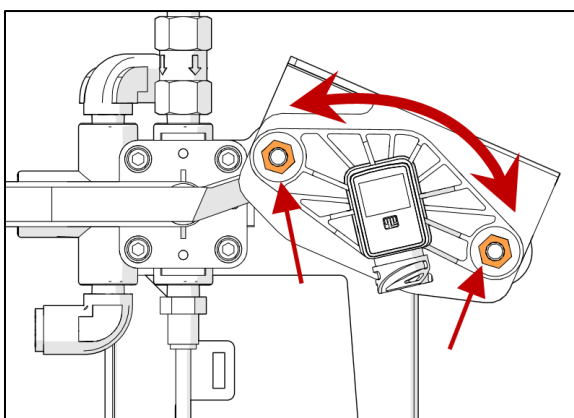


FIGURE 18

36. Using the kneeling dash switch, adjust the vehicle at its maximum height by pressing and maintaining the upper part of the switch. Check the voltage. It should be around 3.5 volts.
37. Using the kneeling dash switch, adjust the vehicle at its minimum height. Check the voltage. It should be around 1.8 volts.
38. Bulletin is complete for this installation.

### H3/X3 FRONT I-BEAM AXLE SUSPENSION (2014-2015)

Order kit # 132119 that contains the following parts:

Part No.	Description	Qty
22194741	SENSOR	1
132126	C-SHAPE ADAPTOR	1
132124	SENSOR ARM ASSEMBLY	1
5001745	SCREW CAP HEX N500 M8X25 G8.8	4
502851	NUT HEX N500 M8-1.25	5
500321	WASHER BELLEVILLE N500 .331X.827X.098(M8,5/16)	5
5001736	FLAT WASHER N500 8.4X18X2 (M8,5/16)	2
504637	CABLE TIE MIDDLE SIZE	4
IS-18025	INSTRUCTION SHEET	1
FI-18025	FEUILLE D'INSTRUCTIONS	1

### PROCEDURE



#### DANGER

Park vehicle safely, apply parking brake, stop the engine. Prior to working on the vehicle, set the ignition switch to the OFF position and trip the main circuit breakers equipped with a trip button. On Commuter type vehicles, set the battery master switch (master cut-out) to the OFF position.

#### EXISTING ARM AND LEVEL SENSOR REMOVAL

39. Raise the vehicle with safe lifting equipment and procedures.
40. Remove cable ties that support the sensor wiring.
41. Unscrew the sensor connector cap and disconnect the wiring.

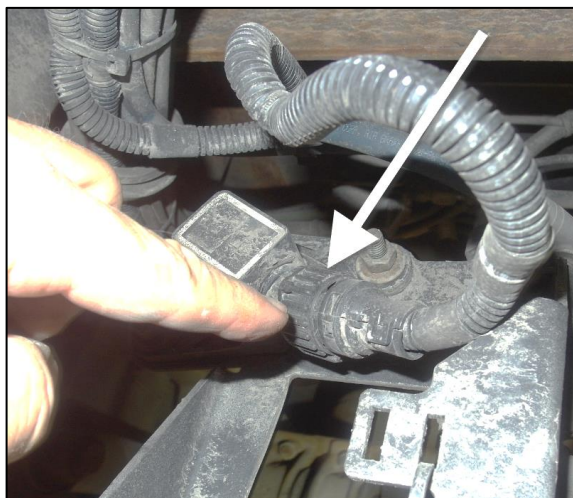
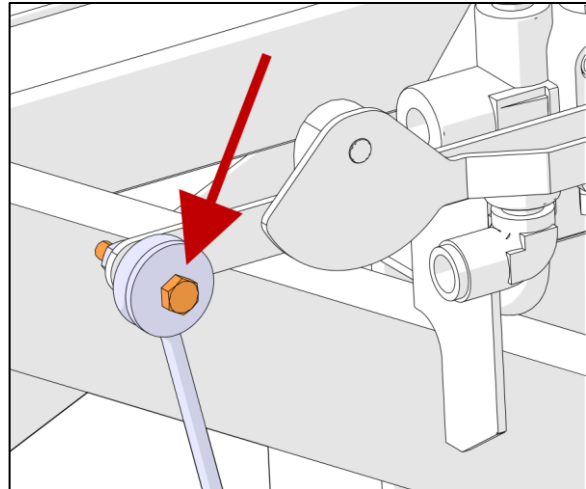


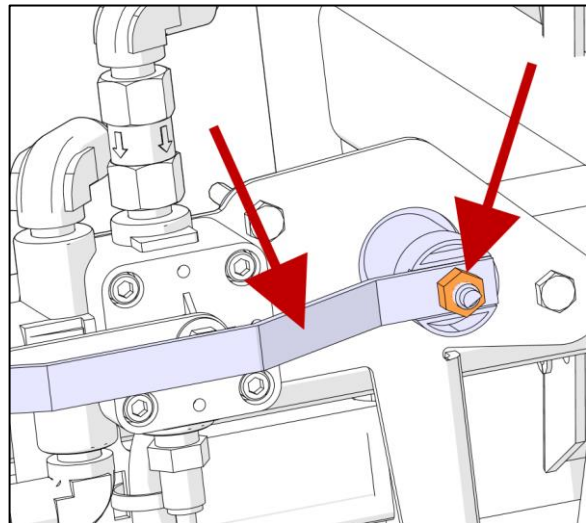
FIGURE 19

- 42. Disconnect the top of the valve connecting rod with the valve lever.
- 43. Keep fasteners for reinstallation.



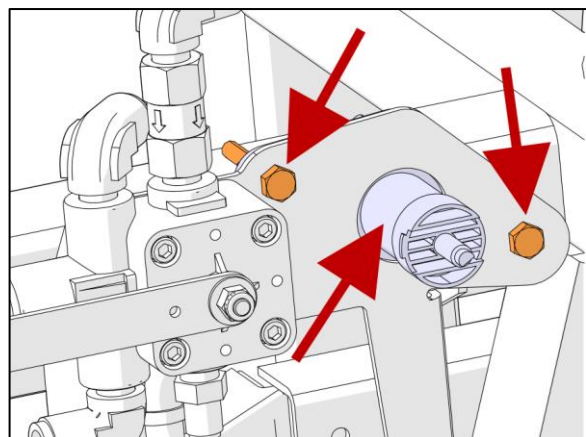
**FIGURE 20**

- 44. Dismount the existing sensor arm from the existing sensor and from the valve lever.
- 45. Discard the arm and the fasteners.



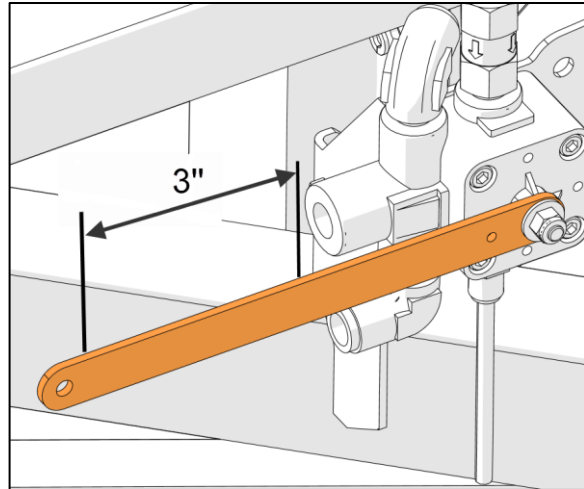
**FIGURE 21**

- 46. Dismount sensor (2 screws).
- 47. Discard sensor and fasteners.



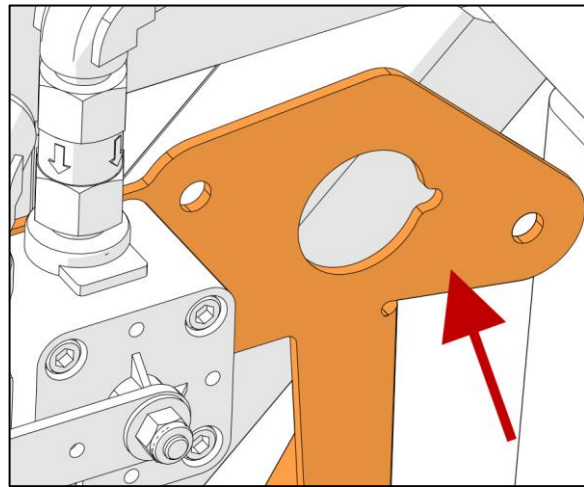
**FIGURE 22**

48. Remove rust on the valve lever, clean it and apply liquid lubricant. Do these operations on four faces and only half of the lever (connecting rod side).



**FIGURE 23**

49. Remove rust on the sensor bracket mounting faces and clean it.



**FIGURE 24**

## NEW ARM AND LEVEL SENSOR INSTALLATION

50. Assemble the sensor with the "C-shape" support.

**NOTE**

*Never alter the sensor for any reason.*

*Make sure the flat on the sensor rotor is orientated as shown in Figure 25.*

**NOTE**

*Screw head must be inside the "C-shape" support.*

*Install flat washers with the screw head side and Belleville washers on the nut side.*

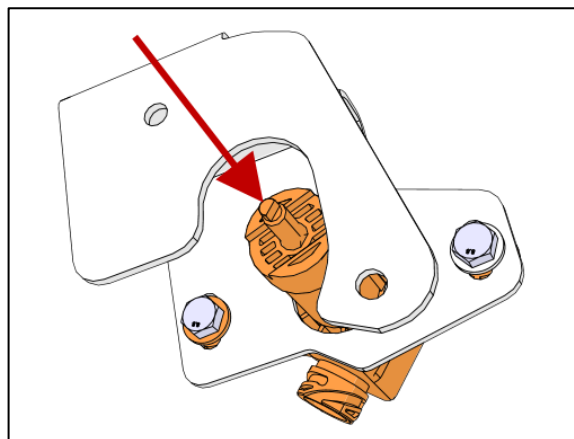


FIGURE 25

51. The "C-shape" support has arced slots to allow angle adjustment of the sensor. Orientate the sensor with the screws in the middle of the arced slots and tighten.

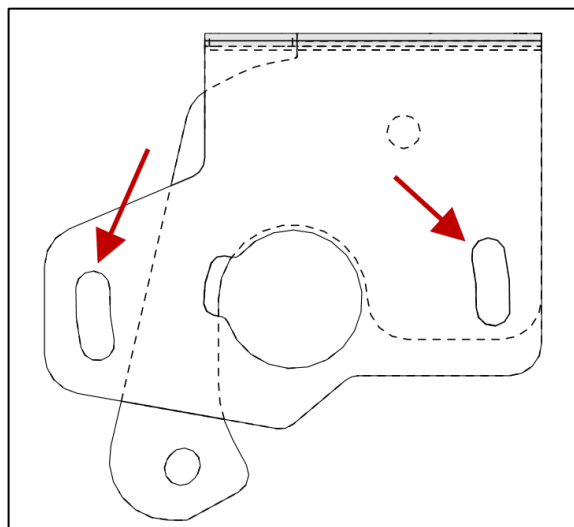


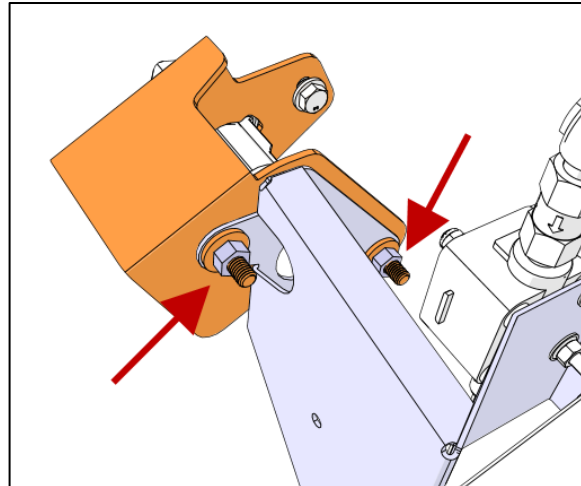
FIGURE 26

52. Install the "C-shape" support with the sensor on the vehicle structural bracket.
53. Tighten the nuts.

**NOTE**

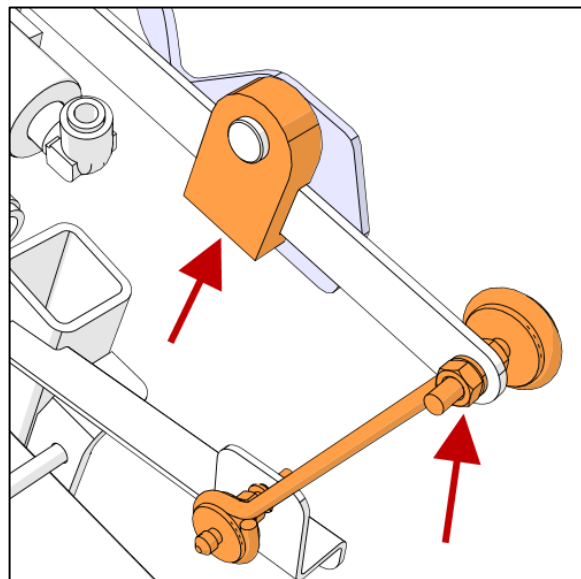
*Screw head must be inside the "C-shape" support.*

*Install Belleville washers on the nut side.*



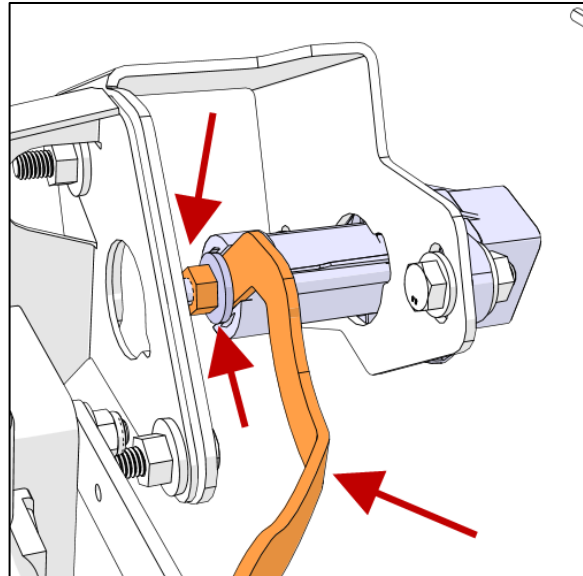
**FIGURE 27**

54. Install the sensor arm slider on the valve lever.
55. Reinstall the connecting rod on the valve lever.



**FIGURE 28**

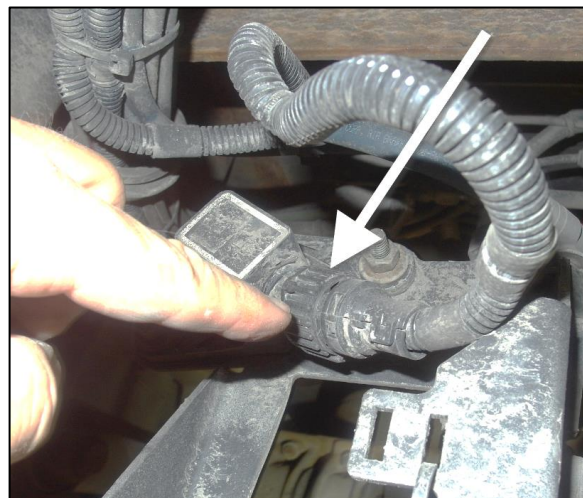
56. Install new arm on the sensor. Use Belleville washer and tighten the nut.



**FIGURE 29**

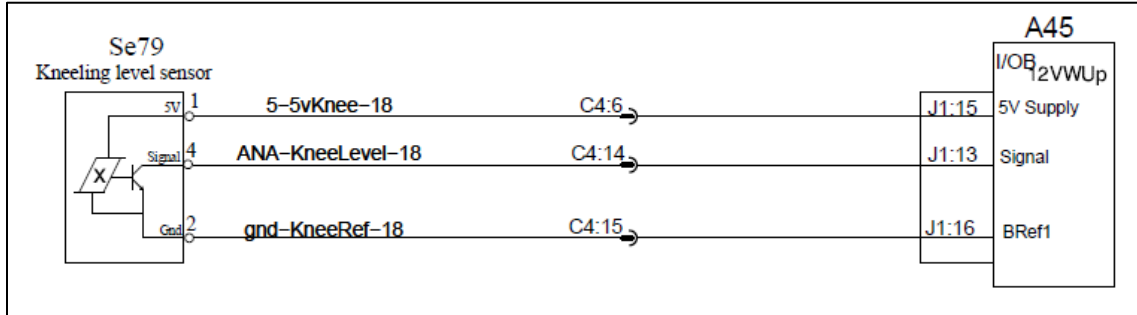
57. Connect existing wiring to sensor and screw the sensor connector cap.

58. Secure the wiring with cable ties.

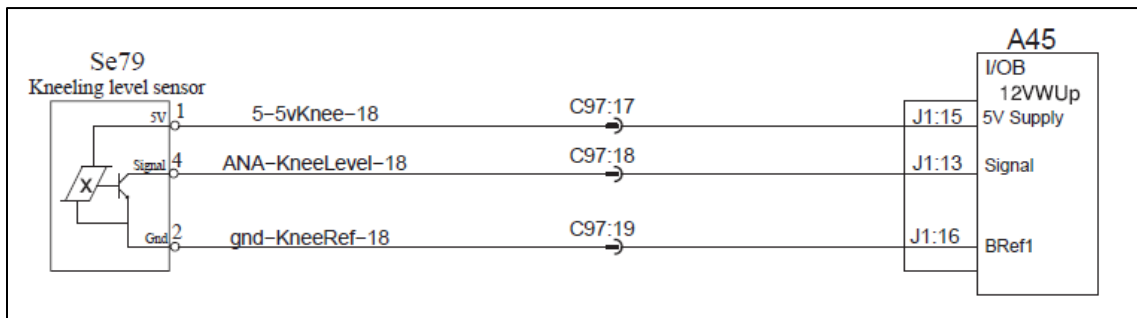


**FIGURE 30**

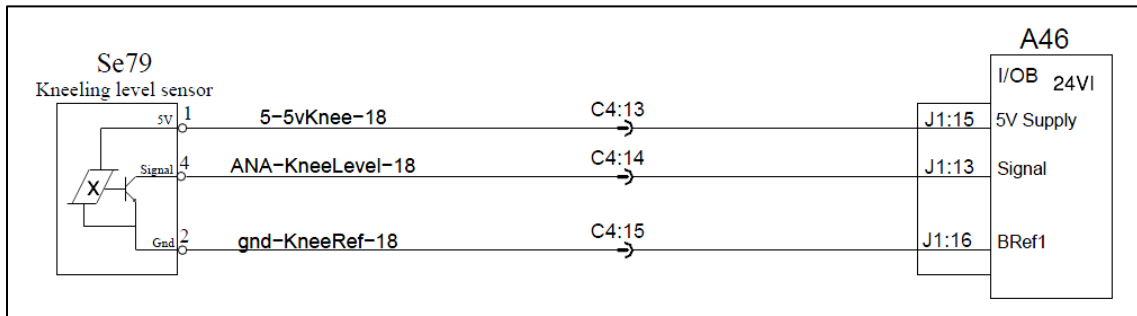
**LEVEL SENSOR ANGLE ADJUSTMENT**



FOR H3 MODELS USE DIAGRAM D061340 P32.1 REV.0 FOR WIRING



FOR X3 MODELS USE DIAGRAM D061350 P32.1 REV.0 OR REV. 8 FOR WIRING



FOR X3 COMMUTER USE DIAGRAM D061380 P32.1 REV.0 FOR WIRING



59. Run the vehicle 5 minutes to fill the pneumatic system with air pressure.

60. Go on the Technical Publications website at this link:

<https://techpub.prevostcar.com/fr/manuels>

61. Select the Technical Manual tab.

62. Enter the short VIN of you vehicle.

63. Select “Maintenance” as Manual type and click on the Search button.

64. Click on “File List” button.

65. Download the Suspension section file.

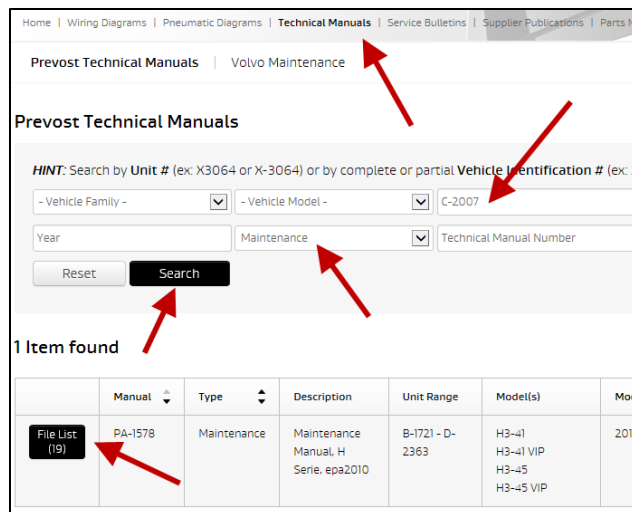


Figure 31

66. Use “spring clearance” words with the search tool to find the information about the clearance for I-Beam and Independent suspension clearance values.

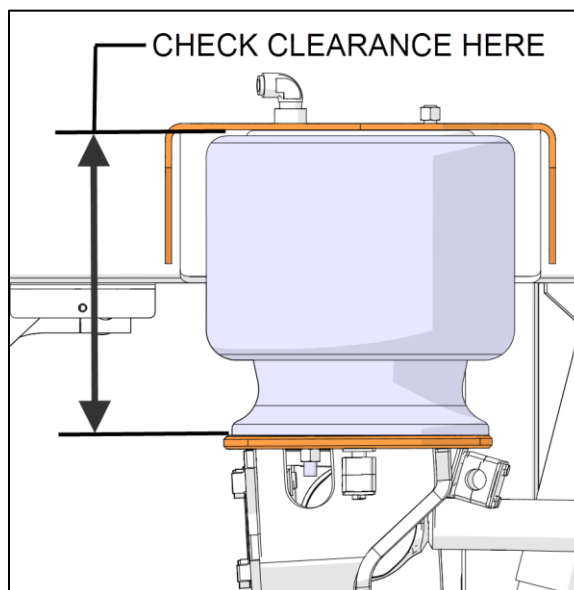


FIGURE 32

67. Into the front service compartment, locate **A45** module for H3 models and X3 models or locate **A46** module for X3-Commuter.

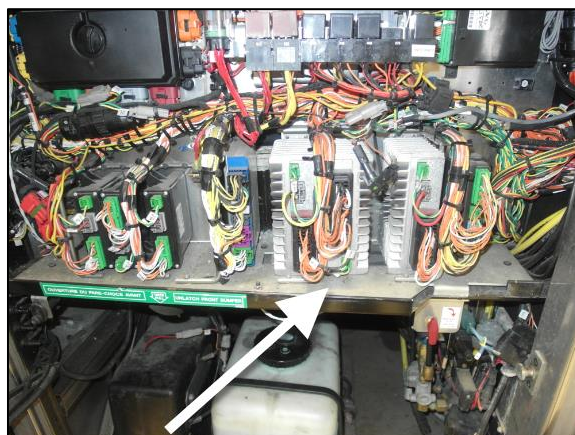


FIGURE 33

68. Locate pin 13 on connector **A45-J1** for H3 models and X3 models or on connector **A46-J1** for X3-Commuter.

**NOTE**

The wire color is white and the wire ID should be "KneelLevel".

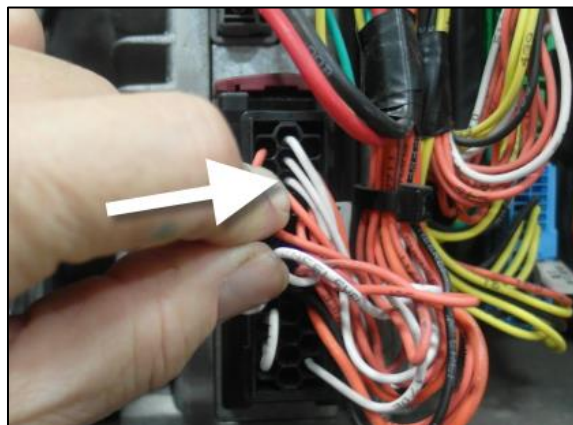


FIGURE 34

69. With a voltmeter, back probe pin 13. The voltage should be around 2.5 volts with the normal clearance.

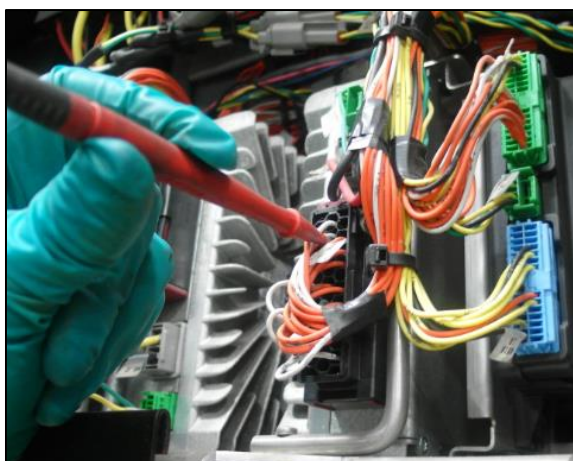


FIGURE 35

70. If the voltage is higher or lower than 2.5 volts, loosen the nuts that fix the sensor to the "C-shape" support and apply a slight rotation.
71. Tighten the nuts, check the suspension below clearance and the voltage.
72. Repeat previous steps until you reach 2.5 volts with the normal clearance.

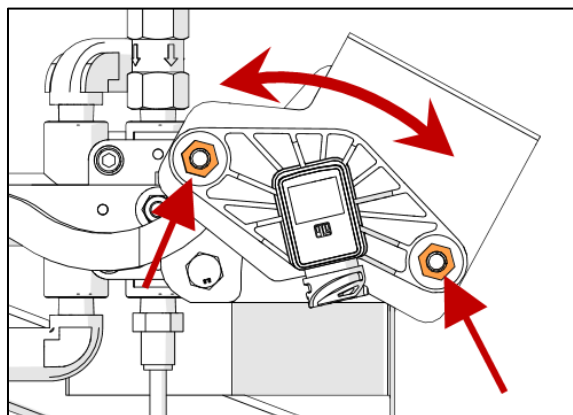


FIGURE 36

73. Using the kneeling dash switch, adjust the vehicle at its maximum height by pressing and maintaining the upper part of the switch. Check the voltage. It should be around 3.5 volts.
74. Using the kneeling dash switch, adjust the vehicle at its minimum height. Check the voltage. It should be around 1.8 volts.
75. Bulletin is complete for this installation.

### H3/X3 INDEPENDENT FRONT SUSPENSION (2012-2013)

Order kit # 132118 that contains the following parts:

Part No.	Description	Qty
132127	KNEELING VALVE SUPPORT	1
132128	PIVOT ARM FOR ECS CAPTOR	1
22194741	SENSOR	1
5001736	FLAT WASHER N500 8.4X18X2 (M8,5/16)	2
5001745	SCREW CAP HEX N500 M8-1.25X25 G8.8	2
500247	NUT HEX N500 1/4-20	2
500321	WASHER BELLEVILLE SPR N500 .331X.827X.098(M8,5/16)	3
500473	LOCK WASHER SPLIT Z050 .262X.489X.062 (M6,1/4,#)	2
500778	NUT HEX N500 5/16-18	3
500836	SCREW CAP HEX N500 5/16-18X.75 G5	3
500942	LOCK WASHER SPLIT N500 8.1X14.8X2 (M8,5/16,#18)	3
502570	LOCK WASHER SPLIT SS 6.1X11.8X1.6 (M6,#12)	4
502622	SCREW CAP HEX SS NSS M6X20 FT	4
502851	NUT HEX N500 M8-1.25	3
504637	CABLE TIE (MIDDLE SIZE)	4
630231	LINK ASSY 185MM C/C 7 1/4"	1
641380	FP ST #8 X 1/4PM	1
FI-18025	FEUILLE D'INSTRUCTION	1
IS-18025	INSTRUCTION SHEET	1

### PROCEDURE



#### **DANGER**

Park vehicle safely, apply parking brake, stop the engine. Prior to working on the vehicle, set the ignition switch to the OFF position and trip the main circuit breakers equipped with a trip button. On Commuter type vehicles, set the battery master switch (master cut-out) to the OFF position.

## EXISTING ARM AND LEVEL SENSOR REMOVAL

76. Raise the vehicle with safe lifting equipment and procedures.
77. Remove cable ties that support the sensor wiring.
78. Unscrew the sensor connector cap and disconnect the wiring.

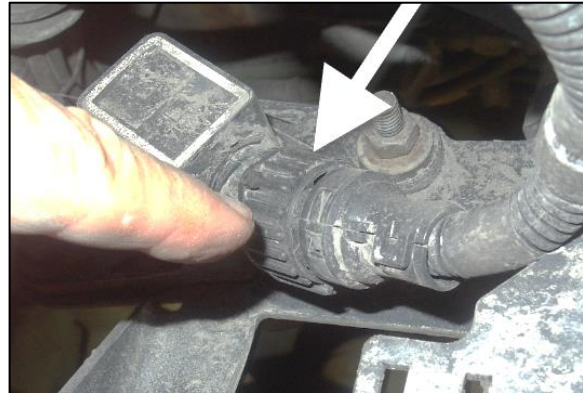


FIGURE 37

79. Dismount all the components shown in FIGURE 38. Do not dismantle the collar on the sway bar. Do not disconnect the piping and the tubing.

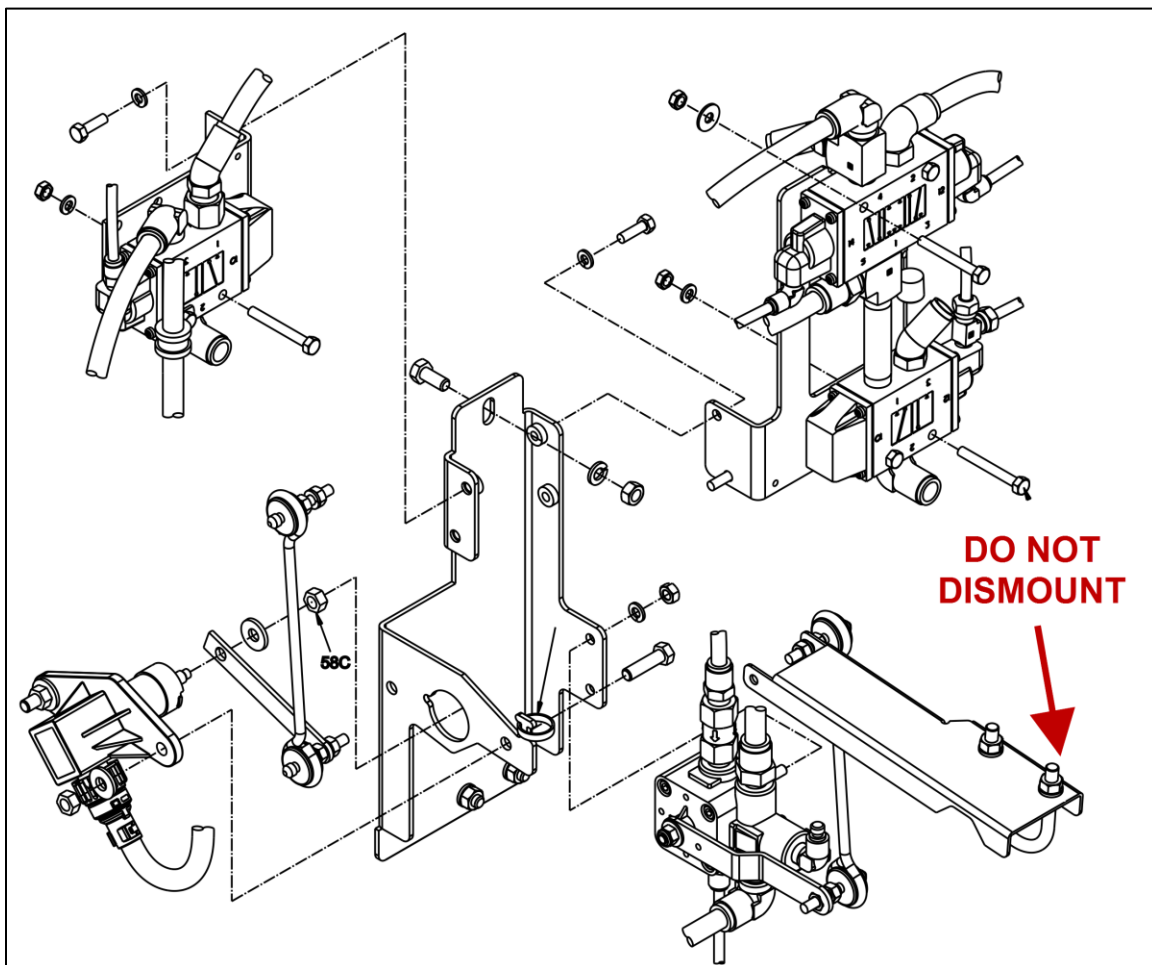


FIGURE 38

80. Install new valve support 132127 with 3 new screws 500836, 3 new lock washers 500942 and 3 new nut 500778.

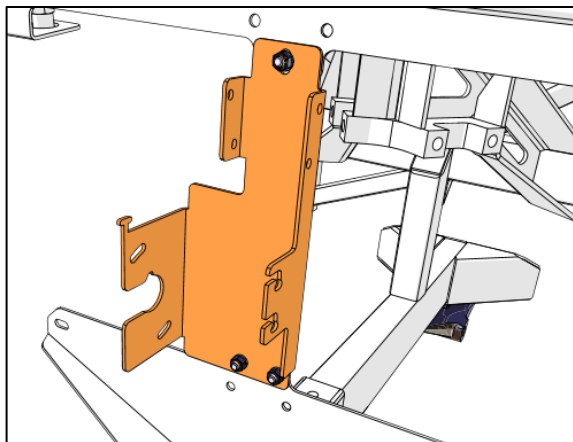


FIGURE 39

81. Reinstall both top valves on the valve support with 4 new screws 502622 and 4 new lock washers 502570.

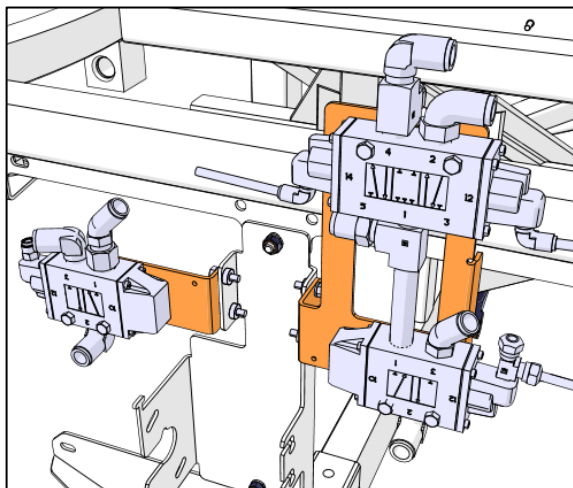


FIGURE 40

82. Replace the elbow fitting under the bottom valve with fitting #641380.  
83. Reconnect the tube on the new fitting.  
84. Reinstall the bottom valve on the valve support with 2 new nuts #500247 and 2 new lock washers #500473.

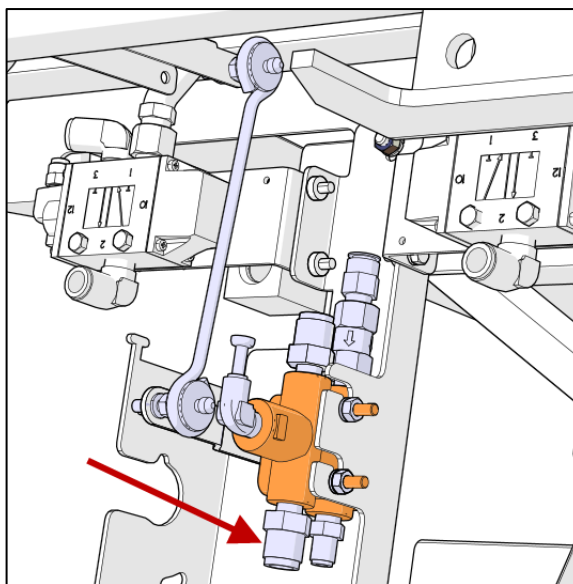


FIGURE 41

85. Assemble the sensor with the new valve support with 2 new screws 5001745, 2 new flat washers 5001736, 2 new Belleville washers 500321 and 2 new nuts 502851.

**NOTE**

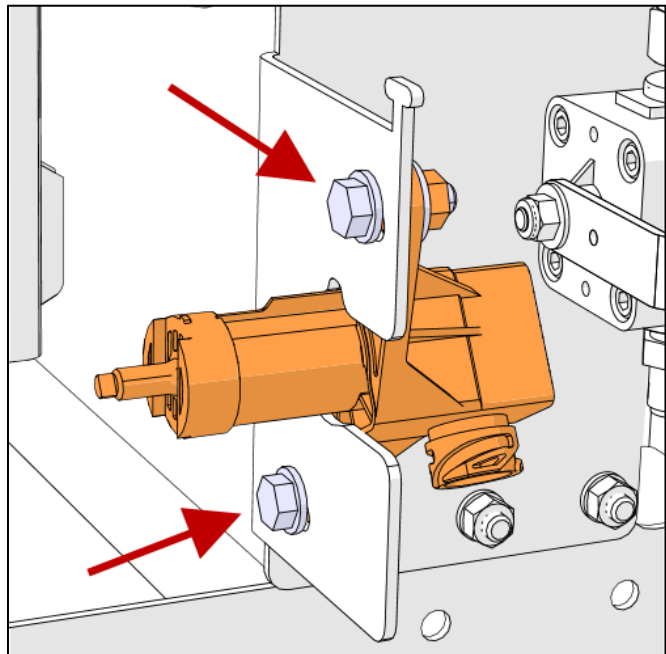
*Never alter the sensor for any reason.*

*Make sure the flat on the sensor rotor is orientated as shown in Figure 42.*

**NOTE**

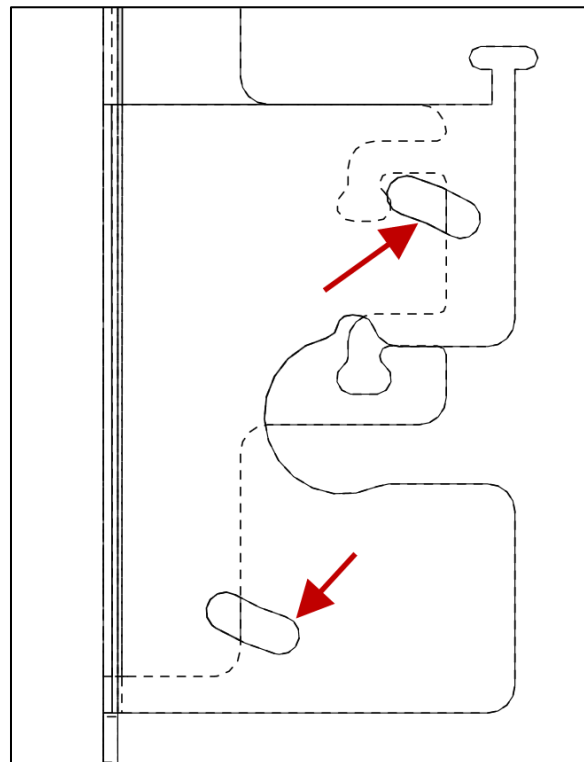
*Screw head must be outside the support.*

*Install flat washers with the screw head side and Belleville washers on the nut side.*



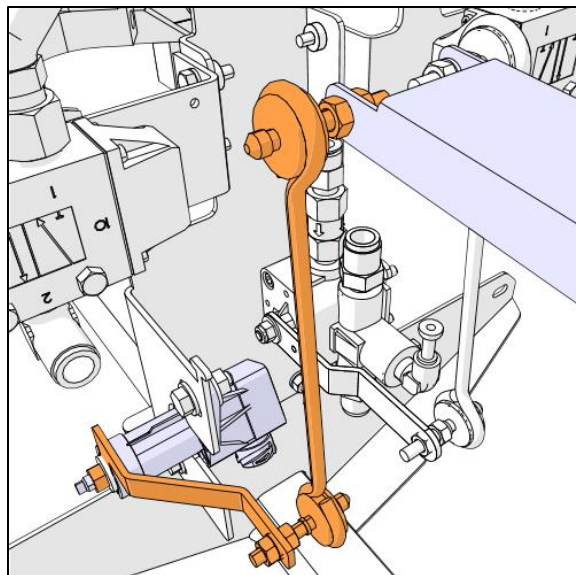
**FIGURE 42**

86. The new support has arced slots to allow angle adjustment of the sensor. Orientate the sensor with the screws in the middle of the arced slots and tighten.



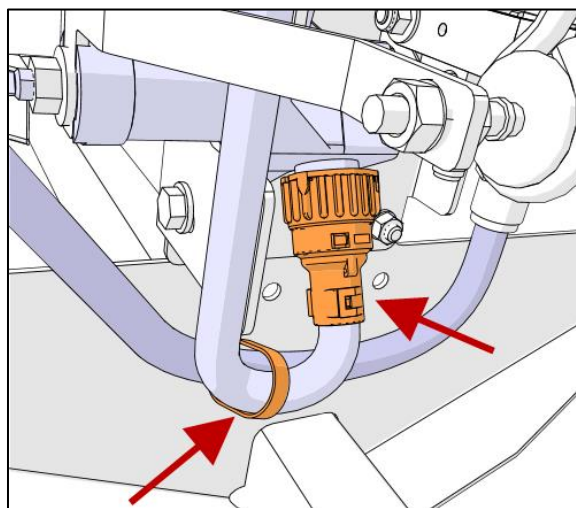
**FIGURE 43**

- 87. Install the pivot arm with a new Belleville washer 500321 and a new nut 502851.
- 88. Install a new link assembly 630231.
- 89. Tighten nuts.



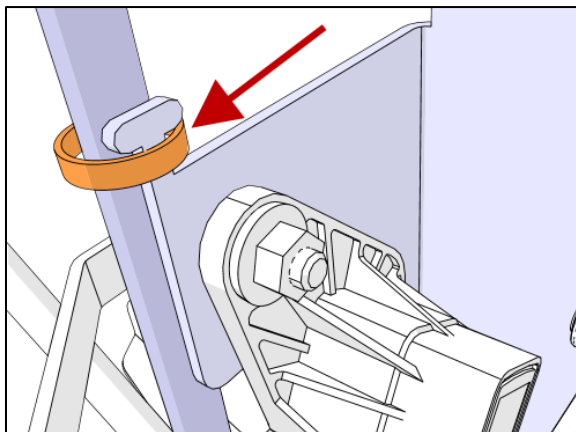
**FIGURE 44**

- 90. Connect the existing wiring on the new sensor and screw the connector cap.
- 91. Secure the sensor wiring with the existing tube with a cable tie.



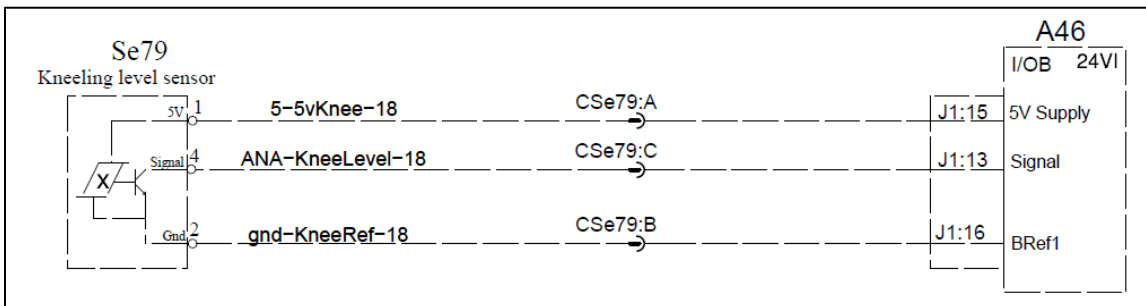
**FIGURE 45**

- 92. Secure the sensor wiring with cable ties as shown in Figure 46.

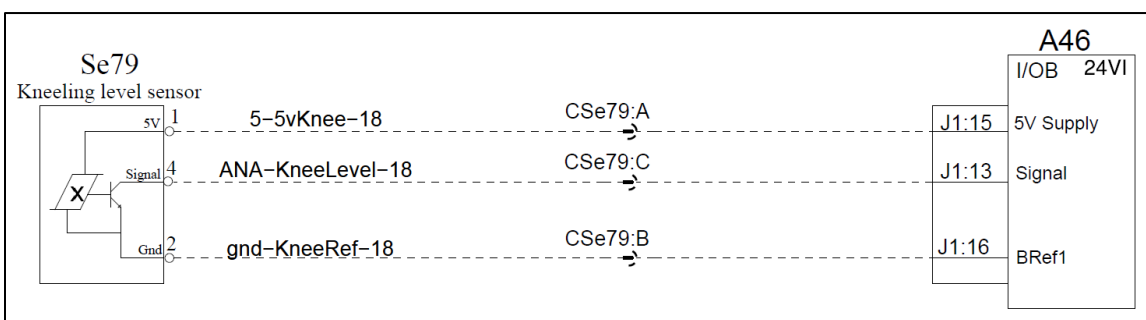


**FIGURE 46**

## LEVEL SENSOR ANGLE ADJUSTMENT



FOR H3 MODELS USE DIAGRAM D061140 P32.1 REV.04 or REV.06



FOR X3 MODELS USE DIAGRAM D061150 PAGE 32.1 REV.8

93. Run the vehicle 5 minutes to fill the pneumatic system with air pressure.

94. Go on the Technical Publications website at this link:

<https://techpub.prevostcar.com/fr/manuels>

95. Select the Technical Manual tab.

96. Enter the short VIN of you vehicle.

97. Select "Maintenance" as Manual type and click on the Search button.

98. Click on "File List" button.

99. Download the Suspension section file.

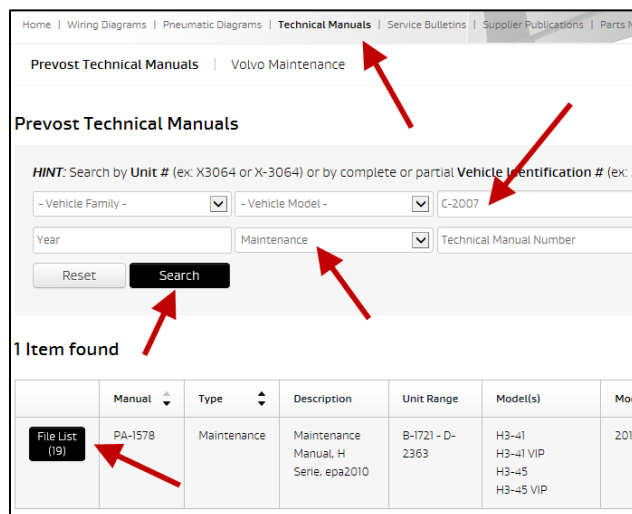


Figure 47



100. Use "spring clearance" words with the search tool to find the information about the clearance for I-Beam and Independent suspension clearance values.

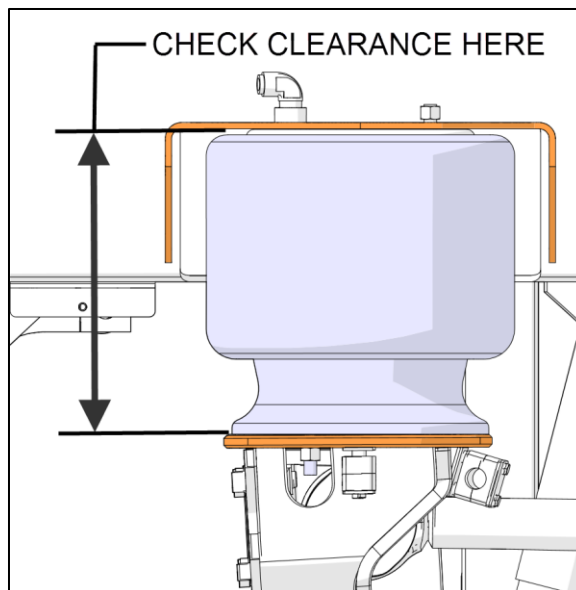


FIGURE 48

101. Into the front service compartment, locate **A46** module.



FIGURE 49

102. Locate pin 13 on connector **A46-J1**.

**NOTE**

The wire color is white and the wire ID should be "KneelLevel".

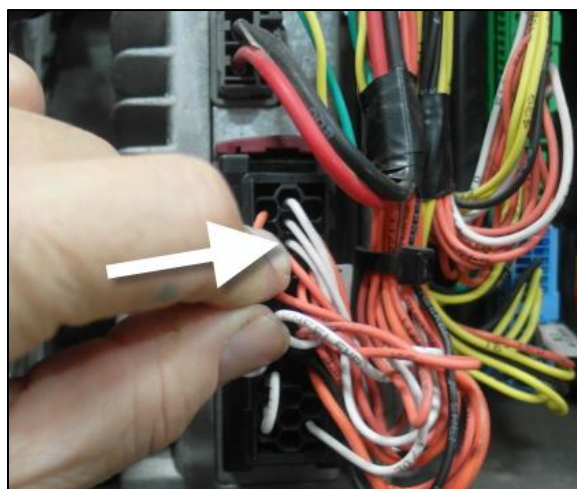


FIGURE 50

103. With a voltmeter, back probe pin 13. The voltage should be around 2.5 volts with the normal clearance.



FIGURE 51

104. If the voltage is higher or lower than 2.5 volts, loosen the nuts that fix the sensor to new valve support and apply a slight rotation.
105. Tighten the nuts.
106. Check the suspension below clearance and the voltage.
107. Repeat previous steps until you reach 2.5 volts with the normal clearance.

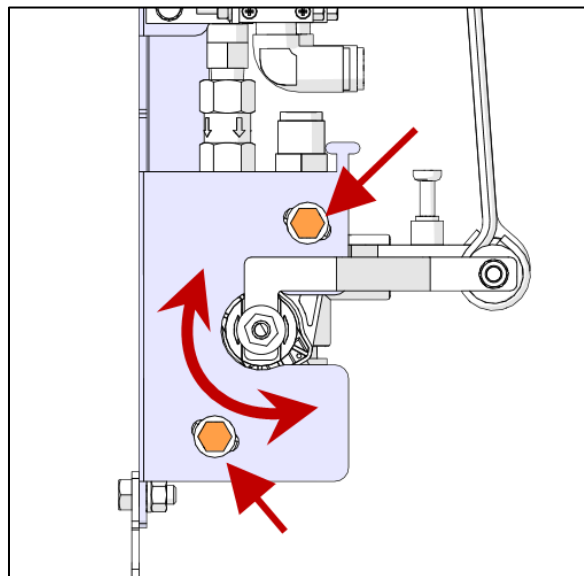


FIGURE 52

108. Using the kneeling dash switch, adjust the vehicle at its maximum height by pressing and maintaining the upper part of the switch. Check the voltage. It should be around 3.5 volts.
109. Using the kneeling dash switch, adjust the vehicle at its minimum height. Check the voltage. It should be around 1.8 volts.
110. Bulletin is complete for this installation.

The time to perform all steps for one installation is 1 hour for vehicles with a front I-Beam axle suspension and 3 hours for vehicles with independent front suspension.

## PARTS / WASTE DISPOSAL

Discard waste according to applicable environmental regulations (Municipal/State[Prov.]/ Federal)