

DDEC III WIRING DIAGRAM

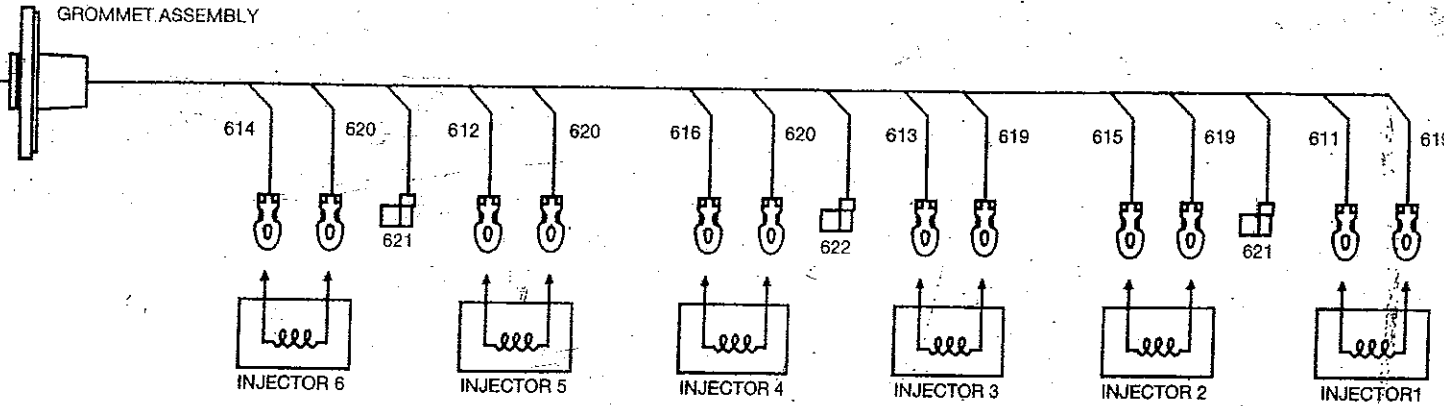

DDC RESPONSIBILITY

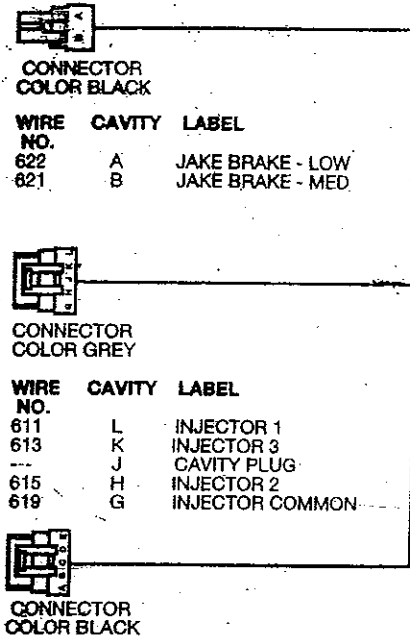

INJECTOR HARNESS SCHEMATIC (SERIES 60 WITH JAKE BRAKES SHOWN)

WIRE NO.	CAVITY	LABEL
612	A	INJECTOR 5
614	B	INJECTOR 6
---	C	CAVITY PLUG
616	D	INJECTOR 4
620	E	INJECTOR COMMON

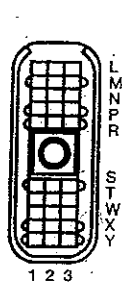

30 WAY CONNECTOR
DDC P/N 12034400
TERMINAL
DDC P/N 12103881

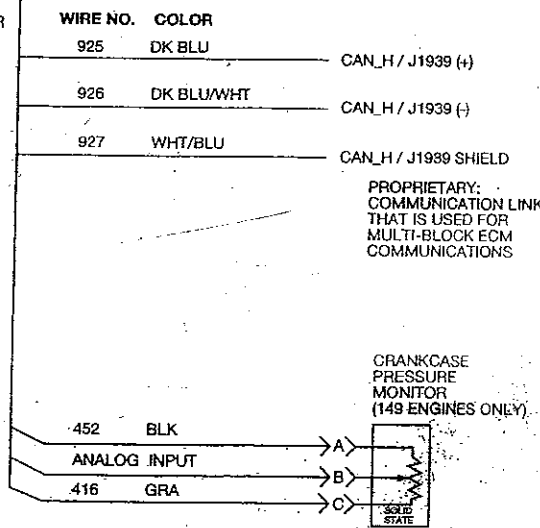

OIL AND COOLANT SENSORS

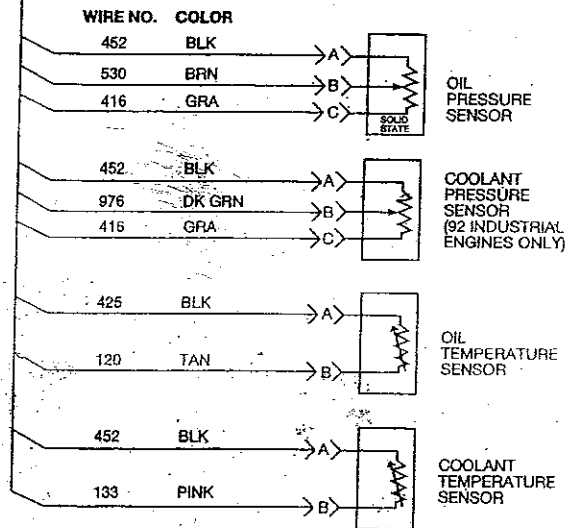

FUEL SENSORS

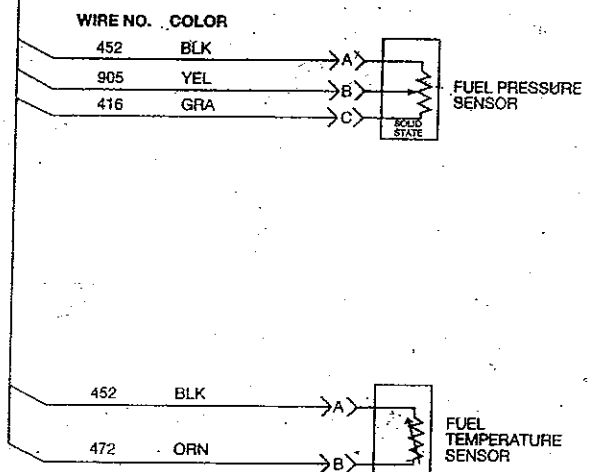

AIR SENSORS

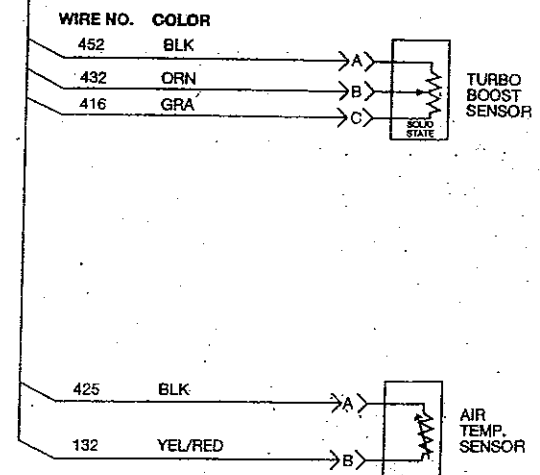

LABEL	WIRE NO.	CAVITY	COLOR
TRS (-)	109	T-1	PPL
TRS (+)	110	T-2	DK GRN
SRS (+)	111	S-2	LT BLU
SRS (-)	112	S-1	WHT
OIL TEMPERATURE	120	R-2	TAN
AIR TEMPERATURE	132	N-2	WHT
COOLANT TEMP	133	P-3	YEL
SENSOR SUPPLY (5VDC)	416	W-1	GRA
TURBO BOOST	432	P-1	DK GRN
SENSOR RETURN (ENGINE)	452	Y-2	BLACK
FUEL TEMP	472	R-3	ORN
OIL PRESSURE	530	P-2	BRN
ENGINE BRAKE MED	561	S-3	RED
ENGINE BRAKE LO	562	T-3	ORN
DIGITAL OUTPUT W-3	563	W-3	YEL
DIGITAL OUTPUT X-3	564	X-3	TAN/BLK
DIGITAL OUTPUT Y-3	565	Y-3	RED
TIMED INPUT	573	X-1	BRN
BARO PRESSURE	904	L-1	PPL/WHT
FUEL PRESSURE	905	M-1	YEL
ANALOG INPUT #3	906	N-1	ORN
ANALOG INPUT #6	907	R-1	DK GRN
PWM OUT #2	909	Y-1	LT GRN/YEL
PWM OUT #3	910	W-2	ORN
PWM OUT #4	911	X-2	PNK
J1939 (+)	925	L-3	DK BLU
J1939 (-)	926	M-3	DK BLU/WHT
J1939 SHIELD	927	N-3	WHT/BLU
ANALOG INPUT #5	958	M-2	BLU
ANALOG INPUT #4	976	L-2	DK GRN

CRANK POSITION SENSORS

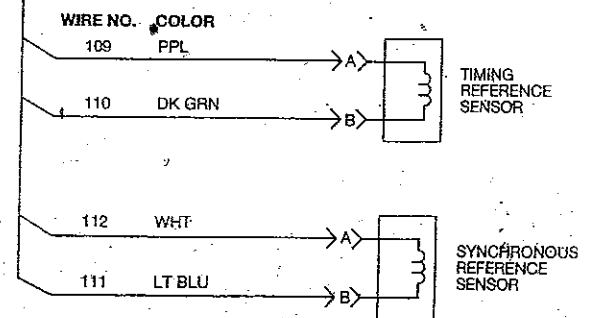

METHANOL ENGINES ONLY

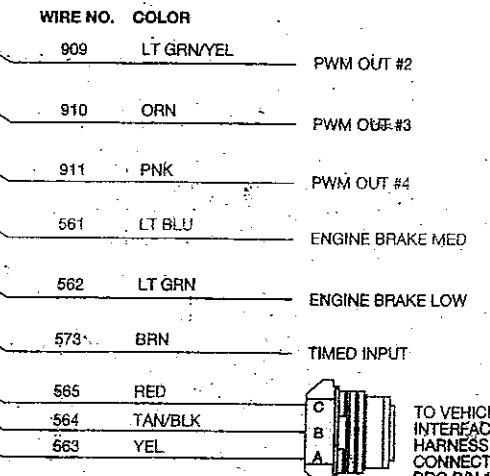
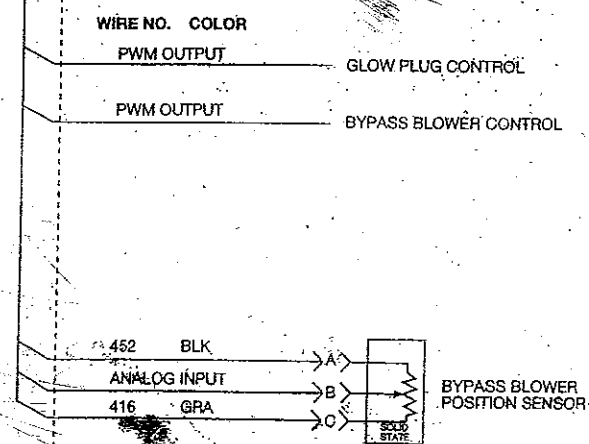

TO VEHICLE INTERFACE HARNESS CONNECTOR
DDC P/N 12110293
TERMINAL
DDC P/N 12048074

